

Made in Italy



CATALOGO GENERALE

GENERAL CATALOGUE



ITALIANO



ENGLISH

POWERED by
HONDA™

www.ecotechitalia.com

SWING
PATENTED
SYSTEM

SWING SYSTEM

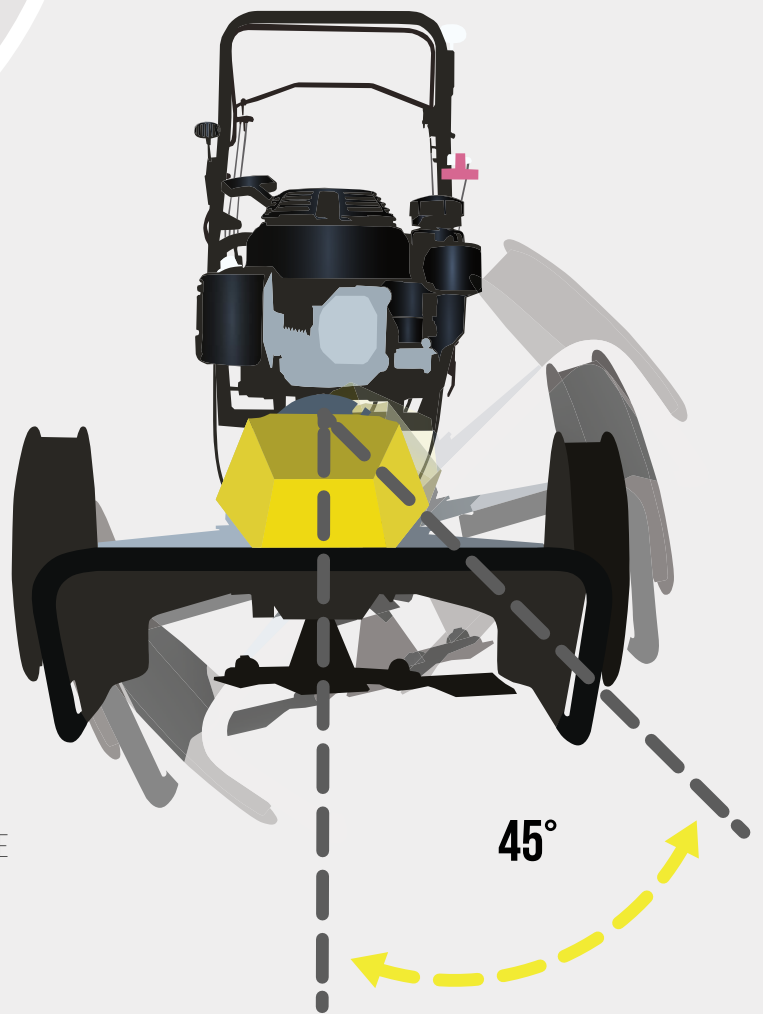

IL SISTEMA A MOTORE OSCILLANTE BREVETTATO PERMETTE DI LAVORARE FINO IN PENDENZE DEL 100% (45°) CON MOTORI A 4 TEMPI. QUESTO SISTEMA PERMETTE DI BLOCCARE AUTOMATICAMENTE L'OSCILLAZIONE DEL MOTORE IN VARIE POSIZIONI A DESTRA E A SINISTRA. MANTENENDO IL MOTORE SEMPRE IN POSIZIONE ORIZZONTALE IL SISTEMA "SWING" NE IMPEDISCE IL GRIPPAGGIO E MIGLIORA LA STABILITÀ IN PENDENZA. L'INCLINAZIONE E' REGOLATA DA UN SEMPLICE E COMODO COMANDO MONTATO SULLE STEGOLE.

THE PATENTED SWING SYSTEM MAKES IT POSSIBLE TO WORK ON SLOPES OF UP TO 45° WITH 4-STROKE ENGINE. THIS SYSTEM ALLOWS YOU TO AUTOMATICALLY SET THE ENGINE SWING AT VARIOUS POSITIONS ON THE RIGHT AND ON THE LEFT, THUS MAINTAINING A HORIZONTAL POSITION, IMPROVING STABILITY AND AVOIDING SEIZING. THE INCLINATION IS ADJUSTED BY MEANS OF A SIMPLE AND CONVENIENT CONTROL PLACED ON THE HANDLEBARS.

SOMMARIO - SUMMARY

SWING SYSTEM 1



7

ML 60 SWING

SERIE 60 - 60 SERIES 3

- DCS 60
- DCS 60 TRACTION
- TRT 60 PRO

SERIE MULTIACCESSORIO - ML SERIES: LAWN MOWERS WITH REPLACEABLE FITTINGS 7

ML 60 SWING

APPLICAZIONI - CUTTING DECKS

SERIE IDROSTATICA - HYDROSTATIC SERIES 10

HSR 110

HSR 135 SWING

HSR 110

10



SERIE 60 - 60 SERIES

La nostra serie 60 comprende decespugliatori, bordatori, trinciatutto, mulchers e rasaerba a scarico laterale per far fronte ad ogni esigenza e ad ogni tipo di taglio. Tutti con motore Honda 4 tempi a benzina con avviamento a strappo, trasmissione a cinghia e meccanica (tranne che per i modelli a spinta), altezza di taglio regolabile da 20 a 100 mm, larghezza di taglio massima 600 mm.

Our 60 series includes brush-cutter lawn mowers also for edges, forestry mowers, mulchers and lateral discharge lawn mowers to meet and satisfy all the demands and for any type of cutting. All with a 4-stroke Honda petrol engine with recoil starter, belt and mechanical drive (except for the walk-behind model), adjustable cutting height of 20 - 100 mm, maximum cutting width of 600 mm.



DCS 60 (COD. 020) - DECESPUGLIATORE A SPINTA -
WALK-BEHIND BRUSH-CUTTER LAWN MOWER



DCS 60 TRACTION (COD. 021) - DECESPUGLIATORE CON
TRAZIONE - DRIVE BRUSH-CUTTER LAWN MOWER

DETTAGLI - DETAILS

Posizioni laterali - Lateral positions

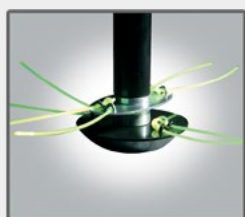

Doppia testina di taglio - Double cutting head



TRT 60 (COD. 042 - 052)- DISBOSCATORE TRINCIATUTTO CON
TRAZIONE - *DRIVE FORESTRY MOWER*

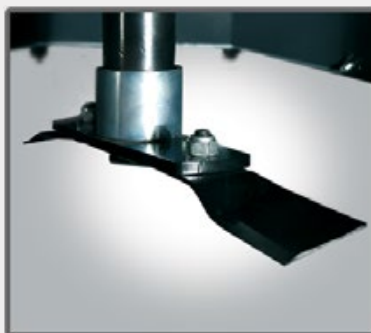

Lama flottante - *Floating blade*



Scarico posteriore regolabile -
Adjustable rear discharge

ACCESSORI - OPTIONALS

Lame in acciaio temprato n. 4/8 pz.- *#4/8 Hardened steel blades*

Ruote dentate in acciaio da 13" - *13" steel crawler wheels*

Filo extra strong n. 20 pz. n. 50 pz.- *Extra strong string # 20 / 50 items*



TRT 60 PRO (COD. 042)- DISBOSCATORE TRINCIATUTTO
 CON MANUBRIO ORIENTABILE A 3 MARCE - *DRIVE FORESTRY MOWER*
 WITH SWING HANDLEBAR AND 3 GEARS

DETTAGLI - DETAILS



Posizioni regolabili manubrio -
Adjustable handlebar positions

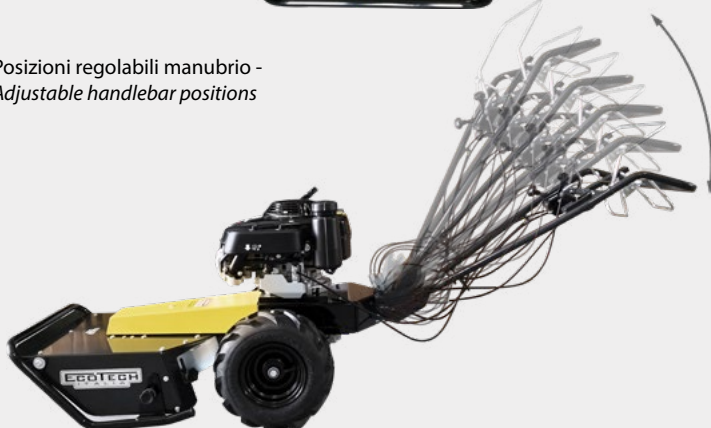

DATI TECNICI TECHNICAL DATA

Motore - *Engine*

Cilindrata - *Displacement*

Trasmissione - *Drive*

Marce - *Gears*

Velocità - *Speed*

Ruote - *Wheels*

Carreggiata - *Track*

Altezza di taglio - *Cutting height*

Larghezza di taglio - *Cutting width*

Peso a secco - *Dry weight*

Livello di potenza sonora garantito -
Guaranteed sound pressure Lwa



DCS 60	DCS 60 TRACTION	TRT 60 PRO
	HONDA GCV 200	Honda GXV 160 Professional
	201 cc	163 cc
--	Cinghia e meccanica - <i>Belt and mechanical</i>	
--	1	3
--	1,6 km/h	1,5 - 1,9 - 3 km/h
16"	Pneumatiche da 13" - <i>13" pneumatic</i>	
600 mm	580 mm	
30 - 45 - 60 mm	30 - 45 - 60 mm	20 → 100 mm
max 600 mm	max 600 mm	500 mm
33 Kg	38 Kg	50 Kg
98 dB	98 dB	96 dB



SERIE MULTIACCESSORIO - ML SERIES



ML 60 SWING (COD. 046 - 056) - MACCHINA
MULTIACCESSORIO OSCILLANTE PER PENDENZE - MACHINE WITH
REPLACEABLE FITTINGS FOR SLOPES

DETTAGLI - DETAILS

CAMBIO ACCESSORI CUTTING DECKS CHANGE

Il cambio degli accessori si effettua in modo rapido e sicuro. L'aggancio fra l'accessorio e la macchina avviene attraverso una semplice presa di forza.

The different cutting decks can be quickly and safely changed using a simple power take-off (PTO).



La nostra serie di macchine multiaccessorio comprende sia modelli trazionati che oscillanti per pendenze fino 45°. Si può scegliere fino a 4 diversi tipi di piatti di taglio intercambiabili sullo stesso corpo macchina e il cambio accessori si effettua in modo rapido e sicuro tramite una semplice presa di forza. Tutti con motore Honda 4 tempi a benzina con avviamento a strappo e trasmissione a cinghia e meccanica.

Our series of lawn mowers with replaceable fittings includes both self-propelled models and models for swinging up to 45° slopes. You can choose up to 4 different types of interchangeable cutting decks on the same machine body and they can be quickly and safely changed using a simple power take-off (PTO). All with 4 stroke Honda petrol engines with recoil starter, belt and mechanical drive.

TRT DISBOSCATORE TRINCIATUTTO - FORESTRY CUTTING DECK



MC MULCHING - MULCHING CUTTING DECK



DCS DECESPUGLIATORE - TRIMMER CUTTING DECK

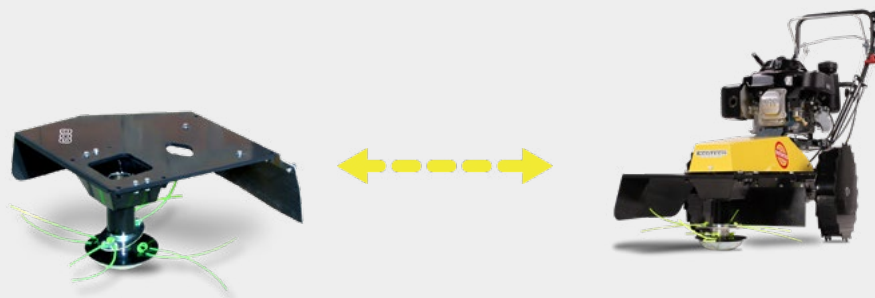

ACCESSORI - *OPTIONALS*



Doppia testina di taglio - *Double cutting head*



Filo extra strong n. 20 pz. n. 50 pz.- *Extra strong string # 20 / 50 items*



Lame in acciaio temprato n. 4/8 pz.- *#4/8 Hardened steel blades*



Ruote pneumatiche da 13" - *13" pneumatic wheels*



Ruote dentate in acciaio da 13" - *13" steel crawler wheels*

DATI TECNICI <i>TECHNICAL DATA</i>	ML 60 SWING
Motore - Engine	HONDA GCV 200 Honda GXV 160 Professional
Cilindrata - Displacement	201cc 163 cc
Trasmissione - Drive	Cinghia e meccanica - <i>Belt and mechanical</i>
Marce - Gears	Variatore di velocità - <i>Speed variator</i>
Velocità - Speed	da 1 a 2,3 Km/h - <i>from 1 to 2,3 Km/h</i>
Freno - Brake	Automatico - <i>Automatic</i>
Oscillazione - Swinging	0° - 15° - 30° - 45° dx-sx (left and right)
Ruote - Wheels	Acciaio dentate da 13" - <i>13" steel crawler</i>
Carreggiata - Track	520 - 780 mm
Peso a secco (senza applicazioni) - Dry weight (without cutting deck)	40 Kg
Livello di potenza sonora garantito - Guaranteed sound pressure Lwa	98 dB

DATI TECNICI APPLICAZIONI - *CUTTING DECK TECHNICAL DATA*

Tipo applicazione - <i>Type</i>	TRT	MC	DCS
Altezza di taglio - Cutting height	30-45-60 mm	30-45-60 mm	30-45-60 mm
Larghezza di taglio - Cutting width	500 mm	500 mm	MAX 600 mm
Peso - Weight	16 Kg	15 Kg	12 Kg
Lunghezza macchina+applicazio- ne - Lenght machine+cutting deck	960 mm	980 mm	780 mm

SERIE IDROSTATICA -HYDROSTATIC SERIES

Nuova serie idrostatica professionale con due motori idrostatici indipendenti dotati di tecnologia SYNCRODRIVE™ che permette di mantenere i motori perfettamente in fase nel tempo. Estrema facilità e rapidità di guida, con leve di comando raggruppate nella parte destra del manubrio e retromarcia istantanea. Tutti con motore 4 tempi Honda professionale a benzina con avviamento a strappo, altezza di taglio regolabile da 20 a 80 mm, larghezza di taglio da 650 a 800 mm. Dotata di manubrio completamente richiudibile per il trasporto.

New professional series with hydrostatic transmission and two independent hydrostatic motors with SYNCRODRIVE™ technology that keeps the two engines perfectly in phase. Extreme ease and rapidity of driving, with the control levers grouped on the right side of the handlebar and instantaneous reverse. All with professional 4-stroke Honda petrol engine with recoil starter, adjustable cutting height from 20 to 80 mm and cutting width from 650 to 800 mm. Equipped with completely foldable handlebar for transportation.

HSR 110 (COD. 771) TRINCIASARMENTI PROFESSIONALE - PROFESSIONAL FLAIL MOWER



Rotore di taglio a 38 coltelli -
Cutting rotor with 38 blades



Regolazione altezza di taglio -
Cutting height regulation

Manubrio totalmente richiudibile per
il trasporto - Full closure handlebar for
transportation

ACCESSORI - OPTIONALS



Ruote elicoidali in acciaio da 16" -
16" helical steel crawler wheels



Kit slitta- Sledge kit

HSR 135 SWING (COD. 786)

TRINCIASARMENTI PROFESSIONALE OSCILLANTE PER PENDENZE - SWINGING PROFESSIONAL FLAIL MOWER FOR SLOPES

DETTAGLI - DETAILS



Rotore di taglio a 46 coltelli da 80 cm -
80 cm cutting rotor with 46 blades

Manubrio totalmente
richiudibile per il trasporto - Full
closure handlebar for
transportation



ACCESSORI - OPTIONALS



Ruote pneumatiche da 16"-
16" pneumatic wheels



100%
(45°)

DATI TECNICI TECHNICAL DATA	HSR 110 SWING
Motore - Engine	Honda GXV 390 Professional
Cilindrata - Displacement	390 cc
Trasmissione - Drive	Idrostatica - Hydrostatic
Retromarcia - Reverse	Istantanea (1,3 Km/h) - Instantaneous (1,3 Km/h)
Velocità - Speed	0 - 5 Km/h
Freno - Brake	Automatico - Automatic
Oscillazione - Swinging	0° - 15° - 30° - 45° dx-sx (left and right)
Ruote - Wheels	Acciaio elicoidali 16" - 16" helical steel crawler
Carreggiata - Track	
Altezza di taglio - Cutting height	20 - 40 - 60 - 80 mm
Larghezza di taglio - Cutting width	680 mm
Peso a secco - Dry weight	150Kg
Livello di potenza sonora garantito - Guaranteed sound pressure Lwa	98 dB

DATI TECNICI TECHNICAL DATA	HSR 135 SWING
Motore - Engine	Honda GXV 390 Professional
Cilindrata - Displacement	390 cc
Trasmissione - Drive	Idrostatica - Hydrostatic
Retromarcia - Reverse	Istantanea (1,3 Km/h) - Instantaneous (1,3 Km/h)
Velocità - Speed	0 - 5 Km/h
Freno - Brake	Automatico - Automatic
Oscillazione - Swinging	0° - 15° - 30° - 45° dx-sx (left and right)
Ruote - Wheels	Acciaio elicoidali 16" - 16" helical steel crawler
Carreggiata - Track	750 - 950 mm
Altezza di taglio - Cutting height	20 - 40 - 60 - 80 mm
Larghezza di taglio - Cutting width	800 mm
Peso a secco - Dry weight	160 Kg
Livello di potenza sonora garantito - Guaranteed sound pressure Lwa	98 dB





**PROFESSIONISTI
DEL TAGLIO IN
PENDENZA**

***PROFESSIONALS
OF CUTTING ON SLOPES***

Area for notes or comments, consisting of a large rectangular box with a dotted border.

Timbro rivenditore - *Dealer stamp*

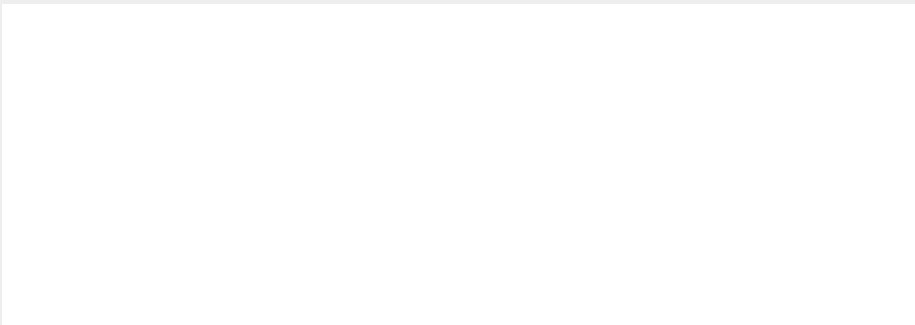

Follow us:



facebook.com/ecotechitalia/



youtube.com/user/razr1978



Via Copernico 85
47122 Forlì - FC - Italy
Tel. 0543-774314
Fax. 0543-778658
email: info@ecotechitalia.com



Regent House
Regent Street
Whitewalls Industrial Estate
Colne
BB8 8LJ

Tel. +44(0)1282 856819
Email. sales@psdgroundscare.com
www.psdgroundscare.com

2020-2021 All rights reserved

www.ecotechitalia.com